

Drum Slot Series

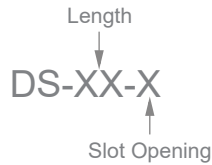
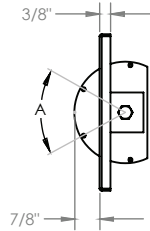
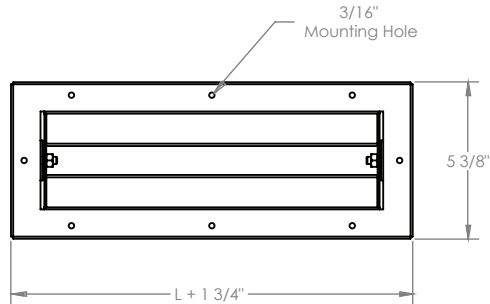

Length	Slot Opening	Duct Opening	Degree Rotation (A)
12	0.5	12 x 4	100°
12	1	12 x 4	85°
12	1.5	12 x 4	70°
24	0.5	24 x 4	100°
24	1	24 x 4	85°
24	1.5	24 x 4	70°
36	0.5	36 x 4	100°
36	1	36 x 4	85°
36	1.5	36 x 4	70°
48	0.5	48 x 4	100°
48	1	48 x 4	85°
48	1.5	48 x 4	70°

(measurements in inches)

Standard Material

- Heavy Gauge Aluminum

Options

- Custom Finish _____

Standard Finishes

- #00 mill
- #12 anodized powder coat
- #42 gloss black powder coat
- #43 flat black powder coat
- #52 white powder coat
- #62 grey primer powder coat (on field painting)
- #72 silver metallic powder coat
- #99 custom color / color match (paint chip needed)

Project :		<h1>DS Series</h1> <p>Drum Slot</p> <p>Form # : 40070S</p> <p>Drawn By : MH May 2026</p>
Architect :		
Engineer :		
Contractor :		
Submitted By :	Date :	