



AIRCONCEPTS

AIR DISTRIBUTION PRODUCTS



PD SERIES

PD

Plaque Diffuser

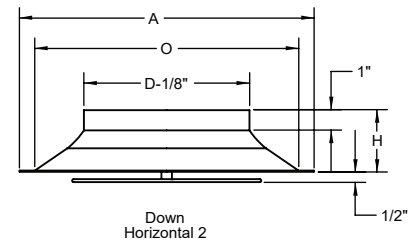
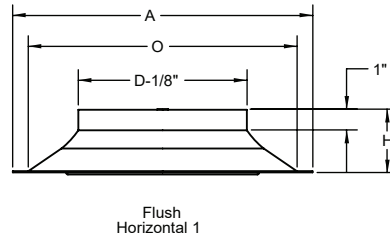

Plaque Diffuser Dimensions in Inches

MODEL	A	D	H	O
PD-06	10-1/2	6	2-1/2	9
PD-08	14	8	3	12-1/2
PD-10	17-1/4	10	3-1/2	15-3/4
PD-12	20-1/4	12	4	18-3/4

PD LI

Plaque Diffuser - Lay-In

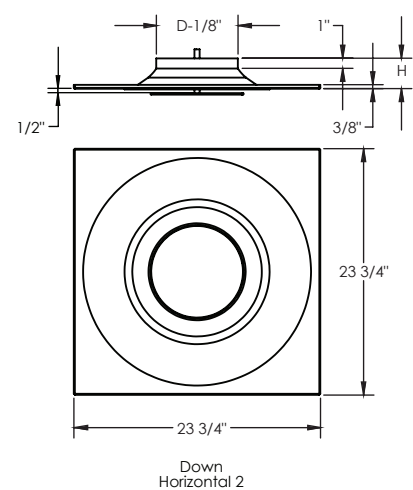
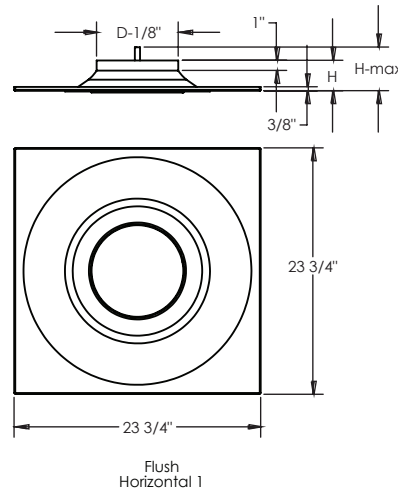

Plaque Diffuser Dimensions in Inches

MODEL	D	H	H-max
PD-06-LI	6	2-1/2	5
PD-08-LI	8	3	5-1/2
PD-10-LI	10	3-1/2	6
PD-12-LI	12	4	6-1/2

High Velocity/ High Aspiration Air Outlet

Distinctive Architectural Design
Adjustable

Construction

Heavy gauge aluminum

Finishes

Standard: #52 White powder coat
Optional standard: #00 Mill
#12 Anodized powder coat
#42 Gloss black powder coat
#43 Flat black powder coat
#62 Grey primer powder coat
#72 Silver metallic powder coat
Custom colors available

MODEL	Duct Velocity (FPM) Velocity Pressure ("WG)	400 0.010	500 0.016	600 0.022	700 0.031	800 0.040	900 0.050	1000 0.062	1200 0.090	1400 0.124
PD-06	CFM	78	98	118	137	157	176	196	235	274
	Total Pressure (Flush)	0.072	0.112	0.162	0.221	0.280	0.350	0.422	0.650	0.884
	Total Pressure (Down)	0.035	0.056	0.080	0.111	0.145	0.185	0.227	0.322	0.444
	NC (Flush)	<15	<15	<15	<15	20	25	28	35	41
	NC (Down)	<15	<15	<15	<15	<15	15	19	25	31
	Radius of Diffusion	1-2-4	2-3-5	2-3-6	3-4-8	3-5-9	4-6-10	4-6-11	5-7-13	5-8-15
PD-08	CFM	140	175	209	244	279	314	349	419	489
	Total Pressure (Flush)	0.056	0.084	0.122	0.166	0.215	0.270	0.330	0.490	0.664
	Total Pressure (Down)	0.032	0.049	0.070	0.097	0.128	0.160	0.197	0.282	0.388
	NC (Flush)	<15	<15	<15	16	21	26	29	36	42
	NC (Down)	<15	<15	<15	<15	<15	16	20	26	32
	Radius of Diffusion	2-3-5	3-4-7	3-4-8	3-5-9	4-5-10	4-6-11	5-7-12	5-8-14	6-10-18
PD-10	CFM	218	273	327	382	436	491	545	654	763
	Total Pressure (Flush)	0.049	0.075	0.104	0.146	0.196	0.230	0.282	0.418	0.584
	Total Pressure (Down)	0.029	0.046	0.064	0.089	0.116	0.148	0.192	0.260	0.356
	NC (Flush)	<15	<15	<15	16	21	26	29	36	42
	NC (Down)	<15	<15	<15	<15	<15	17	21	27	33
	Radius of Diffusion	2-3-6	3-4-8	3-5-10	4-6-11	5-7-13	5-8-14	6-8-15	7-10-18	8-12-22
PD-12	CFM	314	393	471	550	628	707	785	942	1099
	Total Pressure (Flush)	0.038	0.058	0.083	0.113	0.145	0.185	0.222	0.334	0.452
	Total Pressure (Down)	0.027	0.043	0.061	0.084	0.110	0.138	0.170	0.246	0.336
	NC (Flush)	<15	<15	<15	17	22	27	30	37	43
	NC (Down)	<15	<15	<15	<15	15	19	23	29	35
	Radius of Diffusion	3-4-8	3-5-10	4-6-12	5-7-13	6-8-15	6-9-16	7-10-18	8-12-22	10-14-25

performance data based on ASHRAE 70-91

Noise Criteria: Noise criteria [NC] curve which is not exceeded with a Room Attenuation of 10db and based on Sound Power Level Re: 10-12 watts.

Terminal Velocity: Maximum velocity (Vt) in feet per minute at the specified distance from the outlet face (THROW) 150 fpm, 100 fpm and 50 fpm respectively.

Total Pressure: Inches of water gauge required.

Airflow CFM: Standard air density and isothermal conditions.

Radius of Diffusion: Horizontal distance (THROW) in feet from the Diffuser at which the maximum velocity has been reduced to specified terminal velocity (Vt).